

**Lessons from Community Self-
Organization and Cross-Scale Linkages
in Four Equator Initiative Projects**

Fikret Berkes and Cristiana S. Seixas

December 2004

**With the participation of Damian Fernandes, Dean Medeiros,
Stephane Maurice, and Shailesh Shukla**

**Joint Project with the
International Development Research Centre (IDRC)
and the
United Nations Development Programme (UNDP)
Equator Initiative
(www.equatorinitiative.org)**

**Centre for Community-Based Resource Management
Natural Resources Institute, University of Manitoba
Winnipeg, Manitoba R3T 2N2 Canada**

TABLE OF CONTENTS

1. Introduction	1
Community-based conservation	1
Equator Initiative	4
Objectives and study methods	5
2. Case study descriptions	6
The Cananéia Oyster Producers' Cooperative (Cooperostra), Brazil	6
Community-based Arapaima Conservation in the North Rupununi, Guyana	7
Rural Communes' Medicinal Plant Conservation Center (RCMPCC), India	8
Honey Care Africa's Beekeeping in Rural Kenya	9
3. Community self-organization	10
Trigger events and catalytic elements	10
Funding and other resources	11
Capacity building and knowledge systems	12
Leadership and key players	13
4. Cross-scale institutional linkages	15
Main institutional interactions	15
Linkages, networks and political support	15
Funding and other resources	16
Capacity building and knowledge systems	16
Leadership and key players	17
5. Conservation and biodiversity	18
6. Conclusions	19
References	21

LIST OF FIGURES

Figure 1. Key institutional cross-scale linkages that facilitated the creation and development of the Cananeia Oyster Producers' Cooperative, Brazil.

Figure 2. Key institutional linkages facilitating the activities of the North Rupununi District Development Board, Guyana.

Figure 3. Enabling cross-scale linkages that helped achieve project goals, Rural Communes' Medicinal Plant Conservation Center, Pune, India.

Figure 4. Cross-scale interactions of stakeholders in the Kakamega HCA project, Kenya.

Figure 5. Cross-scale interactions of stakeholders in the Kwale HCA project, Kenya.

Figure 6. Organizational cross-scale linkages that enabled the Cooperative to obtain health certification for its oysters, Brazil.

LIST OF TABLES

Table 1. External leaders and their roles, affiliation and connections in the Brazilian case.

Table 2. Role of key individuals: Honey Care Africa Project Officer, Kakamega, Kenya.

Table 3. Cross-scale interactions of stakeholders in the Kakamega HCA project, Kenya.

Table 4. Cross-scale interactions of stakeholders in the Kwale HCA project, Kenya.

1. Introduction

Community-Based Conservation

If conservation and development can be simultaneously achieved, then the interests of both could be served. But to do so is not easy because these two goals (conservation and development) are not necessarily congruent in a given situation (Berkes 2004). More common are situations in which one objective or the other dominates. For example, involving local communities in conservation is often used as a means, a way of making conservation measures more acceptable and less likely to meet local resistance (Brown 2002). But the ultimate objective is one of conservation. Conversely, protecting the productivity of a resource may be used as a means to protect local livelihoods and development options. As the local economy may depend on the ability of the environment to produce ecosystem services such as clean water or forest products, it makes sense to take measures to protect the local ecosystem. But the main objective is local development and livelihoods. Management approaches, sometimes called integrated responses, that explicitly have more than one objective are less common than those that have one primary objective.

The issue is a fundamental one for many areas of natural resource and environmental management. The conventional approach has been to address one objective at a time; however, this approach is no longer sufficient to deal with many of the larger issues of our time. As Ludwig (2001) might put it, the era of management using simple objectives is over. Rather, many of the larger environmental problems of our time, such as climate change, tend to be “wicked problems” or problems of post-normal science. Basically, they are complex problems.

Some large international interdisciplinary team projects, such as the Millennium Ecosystem Assessment (MA 2003), have been working on developing new approaches to deal with these complex problems. The necessity to address two or more management objectives simultaneously is one of the crucial challenges. As dealt by Chapter 15 of the Responses Assessment volume of MA (2005), “integrated responses” are those responses that explicitly and purposely state that their objectives address more than one ecosystem service(s) and human well-being simultaneously. Integrated responses discussed in MA (2005) include sustainable forest management, integrated coastal zone management, river basin and watershed management, and integrated conservation and development projects (ICDP). What these four areas have in common is that they explicitly address both issues of ecosystem services and human well-being.

Integrated responses occur at different scales and across scales. They tend to use a range of instruments, including multi-stakeholder processes, decentralization and devolution policies, partnerships and networks, and multiple institutions and actors, including various levels of government, private sector and civil society. The MA (2005) report highlights integrated responses in these areas, but it is also critical of the experience thus far. In each of these areas, including ICDP, management results have been mixed. Clear-cut examples of successful management have been few and scale-dependent; “success”

often depends on the viewpoint of the observer and the scale of the analysis. Integrated responses may be the future of resource and environmental management, but there is a great deal to be learned.

The issue of scale is one of the critical aspects of integrated responses flagged for further research. Attention to scale is important, and cross-scale approaches are often necessary to deal with complex problems (Cash and Moser 2000). This is because successful responses at one scale tend to encounter constraints at other, often higher, levels. The issue becomes critical in many of the countries of the tropical belt, such as parts of Africa, where institutions at all levels are generally weak (Barrett et al. 2001). Even where community-based institutions are relatively strong, the success of the local system ultimately depends on government institutions and the legal and policy environments in which they operate. These considerations are important for the question of “scaling-up” to bring more benefits to more people over a wider geographic area (Hooper et al. 2004).

However, others have pointed out that success at the community-level can rarely be scaled-up to regional and global levels (Young 2002). That is, there is a major problem if scaling-up is really referring to moving across levels of social and political organization. Hence, the analysis of cross-scale interactions of the kind we discuss here are crucially important. A cross-scale institutions approach may be better able to deal with higher level constraints by taking into account the different nature of each level, and by building on the experience at one level to tackle the problems of the next. Examples of successful cross-scale responses include co-management cases that show feedback learning, that is, adaptive co-management (Olsson et al. 2004).

In general, integrated responses such as ICDP may be seen as a way of moving from problem-solving in simple systems to problem-solving in complex adaptive systems (Berkes et al. 2003). Many of the cases of the Equator Initiative programme are ICDPs. The objective of the Equator Initiative, to address biodiversity conservation and poverty alleviation simultaneously, is clearly an integrated response in the MA sense.

The Equator Initiative

The Equator Initiative is designed to reduce poverty through the conservation and sustainable use of biodiversity in the equatorial belt by fostering, supporting and strengthening community partnerships (EI 2004). The EI is a partnership that brings together the United Nations Development Programme (UNDP) and a number of international and national agencies concerned with conservation and development. Through the cases it fosters, the EI also brings together UNDP and its partners with a diversity of civil society, business, and local groups to help build capacity and raise the profile of grassroots efforts that promote sustainable communities in developing countries.

At the heart of the EI programme is the observation that the world’s greatest concentration of biodiversity is found in the tropics, mainly in countries with rural areas

of acute poverty. Livelihood needs of these people create a threat for biodiversity conservation. However, many “experiments” are underway toward sustainable futures, using local biological resources in creative ways for food, medicine, shelter and improved livelihoods. The EI strives to identify these experiments, reward them, and learn from them. The EI has seven activities. Its flagship activity is the Equator Prize, which has been awarded twice so far, in 2002 and 2004, from hundreds of nominations from various countries.

Research and Learning is one of the seven EI activities. Research and Learning are fostered by enlisting networks of experts and practitioners to use community “best practices”, from the list of Equator Prize winners and nominees, to inform policy and development priorities. Over 400 projects were nominated for each of the 2002 and 2004 Equator Prize competitions. Data on the diverse experiences of Equator Prize nominees is a rich source of information that may be used to understand the factors for successful initiatives. The EI nominees, and especially the projects that are short-listed, provide a set of cases that may be considered successful. In an area such as ICDP in which successes are few, the EI examples provide a particularly promising set of data to explore conditions of success.

There are a number of ways in which EI cases may be analyzed to provide insights. One analysis has used open-ended interviews with representatives for the 24 finalists of the 2004 competition attending the awards ceremony in February 2004 (Seixas et al., submitted). Others have used nomination documentation to search for factors of success (Jonas 2003), to explore possibilities of scaling-up (Hooper et al. 2004), and to develop indicators of conservation and poverty reduction (Rubian and Crowley 2003). Yet others have focused on entrepreneurship as central to understanding the effectiveness of innovations in conservation and development (Juma and Timmer 2003) and analyzed the ecoagriculture set of cases (Isely and Scherr 2003).

Objectives and Study Methods

This report contributes to the Research and Learning component of the EI program by synthesizing the findings of four field studies based on EI cases. Each study addressed the overall purpose of the EI (biodiversity conservation and poverty alleviation) and each addressed the goal of researching lessons from EI cases. Since the number of potential research questions that can be asked is very large (Agrawal 2002), it is necessary to use a targeted approach to narrow research down to a small number of questions. Hence, each study focused on two major common objectives:

- 1) What were the important factors in community self-organization?
What precipitated the project, in terms of trigger events and catalytic elements? How was the project funded and organized? How was capacity developed? What were the sources of information and the role of technical and local/traditional knowledge? What was the role of leadership in the evolution of the project?

2) How can the cross-scale institutional linkages be characterized?

How is the case connected to the various levels of government, to NGOs, and to development agencies through cross-scale linkages? What were the main horizontal (across space) and vertical (across levels of organization) institutional linkages? What cross-scale linkages were important in funding and in knowledge transfer? Which linkages were important for political support and which created institutional barriers?

These two objectives are based on both theoretical and empirical considerations. They emerge out of the theory of complex adaptive systems. A complex system has a number of attributes not observed in simple systems, including nonlinearity, uncertainty, emergence, scale and self-organization (Berkes et al. 2003). Early empirical findings on EI projects (Jonas 2003; Seixas et al., submitted) indicated that scale was important and that many EI projects were characterized by large numbers of cross-scale linkages. Similarly, the genesis of the case and aspects of community self-organization often showed intriguing patterns and variations. A number of meetings were held, involving University of Manitoba researchers experienced in community-based management systems, common property analysis and multi-stakeholder processes, and personnel from the International Development Research Centre (IDRC), Environment Canada and the International Institute for Sustainable Development (IISD). Based on the discussions of these meetings, the analysis of community self-organization and cross-scale linkages were chosen as the focus of the four studies.

Thus, the two common objectives were used in each of the studies, three of them undertaken toward a Masters thesis and one of them a PhD. A common checklist of questions was developed by Seixas and Berkes, in collaboration with the research students, covering the major headings under the two objectives and other important items to characterize the EI case. The four studies covered EI cases in Brazil (BR), Guyana (GY), India (IN) and Kenya (KE); all were from the 2002 Equator Prize competition. Three of the four were from the list of prize finalists; only the Guyana case was not. Each case was studied over a period of three and half to five months in the field, using a mix of quantitative and qualitative methods, including short questionnaires, participant observation, semi-directed interviews, key informants, focus groups and other small group interviews. A description of cases may be found in the next section of this report.

2. Case study descriptions

The Cananéia Oyster Producers' Cooperative (Cooperostra), Brazil (BR) (researched by Dean Medeiros)

Cooperostra works toward adding economic value to a natural resource (oyster) while intending to conserve the mangrove ecosystem. Cooperostra members collect oysters from the mangrove, keep them in human-made oyster rearing beds to grow to larger, more profitable sizes, and then purify the oysters in a depuration station in order to obtain health certification from the Federal Inspection Agency for commercialization. With such

certification, Cooperostra members can command higher prices for their oysters and sell them directly to high-end restaurants, instead of selling to middlemen who would claim the large portion of the profits.

The Cooperostra idea emerged from a study on the socio-economic viability of extractive reserves (protected areas that allow certain kinds of resource use) in Cananéia, conducted by two São Paulo state government agencies (the Forest Foundation and the Fisheries Institute) and a university research group (NUPAUB/USP) with support from the Federal Environmental Agency (CNPT/IBAMA). These organizations, in particular the two state agencies, have worked together to obtain funding, build local capacity, organize cooperative members, and connect the cooperative with other organizations and the regional oyster market. Cooperostra was initially created for the Mandira community, situated within an extractive reserve, the population of which has relied on oyster harvesting for more than 90% of their livelihood earnings. Nevertheless, due to logistical considerations regarding the construction of the depuration station, oyster collectors from other communities also became members.

Cooperostra has succeeded in improving the incomes of its members who now harvest fewer oysters and have more time to pursue other activities. Cooperostra members mentioned that they have observed an increase in oyster stocks despite the lack of oyster stock assessment and biodiversity benchmark data. They have also learnt the importance of protecting the mangrove. In addition, the establishment of the Mandira extractive reserve (an initiative linked to Cooperostra) turned an open access area into a community-based one. Despite of such successes, Cooperostra has faced some problems including poor administration over the years (mainly by non-members) leading to debts; poor marketing strategies and transportation system (i.e., insufficient sales leading members to continually sell oysters to middlemen who compete with the Cooperostra oysters); internal conflicts between members from the Mandira community and from other communities; and uneven allocation of benefits among cooperative members.

Community-based Arapaima Conservation in the North Rupununi, Guyana (GY) *(researched by Damian Fernandes)*

The fish, Arapaima (*Arapaima gigas*) is a large, high-value species of the Amazon basin. The North Rupununi District Development Board (NRDDB) is a regional NGO that facilitates the management and development of its 14 member communities. NRDDB manages a number of projects including the Arapaima Management Plan. NRDDB works closely with Iwokrama International Centre (a national NGO) responsible for managing a rainforest reserve. Iwokrama has facilitated NRDDB projects by providing training, capacity building, and technical and institutional support, by creating links between NRDDB and government or other organizations, and by providing funding or helping NRDDB to search funding for their projects.

The Arapaima fishery is legally prohibited in Guyana, but due to lack of government enforcement, Arapaima populations have been over-harvested in some areas. In 1998, the

North Rupununi communities identified Arapaima management as a local priority. Iwokrama facilitated then the link between NRDDDB and the Mamirauá Sustainable Development Reserve in Brazil – a project that was successfully conducting adaptive co-management of *Arapaima gigas* using local ecological knowledge to assess populations and estimate sustainable harvest levels. Scientists and fishermen from the Mamirauá Reserve helped NRDDDB with the development of the Arapaima Management Plan. In 2000, a ban of Arapaima harvest was locally imposed and enforced by NRDDDB members. Between 2001 and 2004, the number of adult Arapaima counted in the managed area increased three-fold. However, there has not yet been any harvesting or direct income generation from Arapaima. But high value markets have been identified for future sales of Arapaima. In addition, alternative sources of income were created including small-scale aquarium fish trade, and salaries to fishers and rental of community equipment to conduct annual Arapaima surveys.

The government supported the project initially but has not contributed much for the development of the Arapaima Management Plan or its implementation. Indeed, lack of institutional memory and political commitment at higher government levels is argued to be a major impediment for the approval of this management plan, which is based on the assumption of eventual sustainable harvests of Arapaima. Although NRDDDB has begun to create links with government and funding agencies independent from Iwokrama, it still lacks strong political links needed to approve the Management Plan.

Rural Communes' Medicinal Plant Conservation Center (RCMPCC), India (IN)
(researched by Shailesh Shukla)

This initiative works toward *in situ* conservation and sustainable use of medicinal plants in the Maharashtra state by promoting a partnership among local communities, the Forest Department (government) and NGOs. RCMPCC facilitated the establishment of 13 Medicinal Plant Conservation Areas (MPCAs) and the creation of local organizations (local management committees and self-help groups of women) in charge of harvesting, processing, marketing and sale of medicinal plants within their designated areas. The initiative aimed to document and disseminate local knowledge of medicinal plants and help to revitalize local health traditions. Through participatory approaches, it was able to document some 50,000 medicinal plants representing more than 50 different species. The initiative was launched in December 1999 but community-based activities commenced in August 2002. Since then, it has inspired other states and the Government of India to include MPCAs in their conservation and development agendas.

The initiative emerged from the idea to expand an earlier project of the Foundation for Revitalization of Public Health Traditions (FRLHT) (a national-level NGO) with the support from Rural Commune (a regional NGO) who had previously worked with the state Forest Department. Funding availability created an opportunity to implement the project. Training and capacity building in different issues were provided by local and outside experts to community members and government agents at various stages of the project implementation.

This initiative is quite recent and has no baseline data collection; hence it is premature to assess impacts on biodiversity conservation and poverty reduction. Nevertheless, MPCAs are becoming a major gene pool of plant diversity in Maharashtra. As well, valorizing and popularizing the local low-cost alternative health products contributed to the improvement of health and nutrition of poor people. In addition, the initiative empowered women's groups to become economically self-reliant and participate in community decision-making processes.

Honey Care Africa's Beekeeping in Rural Kenya

(researched by Stephane Maurice)

Honey Care Africa (HCA) is a private company that has promoted over a dozen beekeeping projects in rural communities throughout Kenya. HCA has established partnerships with local development organizations (NGOs or community-based organizations) and rural communities, particularly with small-scale farmers (beekeepers). HCA introduced a new beehive technology in these communities and guaranteed to purchase all honey produced by individuals with cash payment at a competitive, fair price. The partnering organizations facilitated the project implementation in each area by providing training and capacity building, supervising the hives, in some cases providing loans for individuals to purchase beehives, and also by mediating the relationship between HCA and beekeepers so that the former does not exploit the latter. Government agents from the Ministry of Livestock and Fisheries Development (MLFD) are also engaged in some of the projects.

In our research, two of the HCA projects were investigated in the field: one in the Kakamega district (KE-I), a densely populated area near a rainforest; and the other in the Kwale district (KE-II), with a relatively low population density and located largely in a semi-arid region. Both HCA projects initiated in 2000.

In Kakamega, the Community Action for Rural Development (CARD – a community-based organization) supervises more than 600 HCA beehives, managed by beekeeping groups or individual beekeepers. A similar amount of hives is under the supervision of the Coastal Rural Support Program (CRSP) of the Aga Khan Foundation (a national NGO) in the Kwale district. In this area, CRSP partnered with government agents of the Ministry of Livestock and Fisheries Development, based in CRSP's office, in order to implement the beekeeping project. In Kwale, CRSP tried to organize Village Development Committees (VDC) and Village Development Organizations (VDO) to facilitate many of the AKF projects, including beekeeping. Nevertheless, many of these VDC and VDO were not functioning well due to lack of leadership and continuously technical and organizational support from CRSP.

In Kakamega, beehives are owned individually but often managed collectively, an arrangement that encourages information exchange. The existing local knowledge about bees and beekeeping using traditional technologies helped the project succeed in this

area. In Kwale, beehives are owned and managed individually, and there is poor information management and dissemination of knowledge among beekeepers from different villages. Moreover, few people had previous experience with beekeeping. These facts, in addition to weak technical support and limited flower (nectar) resources due to low precipitation in certain months of the year has constrained the project's success.

The pollination service provided by bees to both wild and cultivated species is expected to help conservation. However, in none of these two areas a study on the impact of beekeeping in the environment has been conducted, despite some people mentioned an increase in fruit crop yields and more flowers and fruits being planted. The project contribution to reduce poverty is also mixed. Those few beekeepers that paid back their loans think the project is worthwhile, but the large majority have paid off very little of their loans yet. Another important point to consider is that this project favors individuals with disposable income, or the wealthier members of the village, as the poorest villagers do not have the capital to purchase hives.

3. Community self-organization

Trigger events and catalytic elements

Even though all four projects have produced community benefits, in three (BR, IN, KE) out of the four projects, the initial idea for the initiative came from organizations (government, NGO or private sector) outside of the local communities. The Guyana project was the only one that emerged from a community demand (priority) to manage Arapaima populations and was facilitated by a national NGO (Iwokrama).

In Brazil, two government agencies at state level, working collaboratively with a University group, come together with the idea in face of a decrease in resource yields due to high extraction pressure during the implementation of an extractive reserve. The reserve guaranteed community property rights over resources. A call for project proposal to be funded by the federal government became a catalytic element in developing the project.

In India, the project borrowed its vision from earlier work by a national NGO in other states of the country on community health improvement. The expansion plan of this NGO with the readiness of a partner NGO at the regional level, backed up by funding support from the UNDP, made it happen.

In Kenya, a private company saw an opportunity to develop a high-end product to serve the domestic market in larger centers that had been served by foreign producers. At the same time, the company provided local farmers with a complementary livelihood activity with potential environmental benefits. This company held a series of public demonstrations on a new technology promoting beekeeping in rural communities.

In the Brazilian and Indian cases, government agencies worked together with NGOs and/or research groups in face of funding availability to start the projects. In Brazil, the process was driven mainly by government agencies while in India the national and regional NGOs initially drove the process. Several workshops involving outside players and community groups were critical for the implementation of the projects in all cases. In Guyana and India, the projects were inspired on similar experiences elsewhere in the country (Indian case) or in another country (Guyanese case). In Brazil, government agencies built on previous attempts to introduce aquaculture in the area. That is, in at least three of the cases, there was transfer of know-how and knowledge from other experiences.

Funding and other resources

All the projects needed initial investments. In three of the projects (BR, GY, IN) funding was mainly from international and national funding agencies, sometimes with small contributions from local organizations. In the Kenyan case, part of the money of the Honey Care Africa's local partner organizations came from national and international funding agencies as well, but community members and at least one partner organization had also to come up with their own money to invest in the project.

Funding is needed to start a project (start-up funding) and sometimes to conduct the project (operational funding). **Figure 1** shows how outside funding may be a major enabling factor and how a diversity of sources are often needed. Funding for most (perhaps all) of these projects came from at least five different sources, mainly international ones. In all cases, one of the key organizations involved in the project had previous experience in applying for funding. This knowledge was used to access funds from different sources.

In all cases, funding was used to cover capacity-building costs, including technical training by experts. In Brazil, outside funding was also used to cover costs of equipment, construction, expansion, and operational costs. In Guyana, funding was used to carry out Arapaima surveys and to promote an alternative livelihood option (aquarium fish trade). In Kenya, funding was used to buy beehives by community members and equipment by the partner organization.

It is premature to assess if any of the projects have reached a self-sustaining stage. But it is clear that funding has provided services both for the key organizations and the local communities, and such services are important. For instance, in the Kwale case in Kenya, the infrastructure and vehicle provided by the partnering NGO enabled the government agents to do their work (since they had no office space or vehicles). This helped create a reciprocal relationship, in that the NGO used the existing connections between these government agents and the local farmers to support beekeeping and other projects. In the Brazilian case, the truck bought with the project funding to transport oysters to outside markets was also used to transport goods to the community which is located 25 km away

from the urban area. In the Guyana case, outside funding was used to construct a building that became a multi-purpose meeting space used by the community.

In order to design and implement their projects, most initiatives used some voluntary help and/or free facilities and equipment provided by outside groups and government, NGO or university personnel. This included voluntary help from people paid from other sources but allowed to work in these projects during their free time. Such help included writing proposals (BR, GY, KE, IN), establishing contacts with outside organizations (BR, GY, IN), helping to register community groups and/or cooperatives within the legal system (BR, KE, IN), providing transportation for people to attend meetings (GY), helping organize training (IN), and promoting the project (KE).

In most of the cases, there were clear pre-existing relationships among some of the key groups involved in the initiative before the project started. For instance, in Brazil previous relations were built among the local community, the University group and the Forest Foundation during the implementation of the Extractive Reserve. In Guyana, strong relationship already existed between NRDDDB and the national NGO (Iwokrama). In both Kenyan cases, the partnering organizations (a community-based organization in Kakamega and a NGO in Kwale) were already carrying out development work with local farmers before the Honey Care project started. The Indian case was the only one with no obvious direct pre-existing relationships among the organizations implementing the project on the ground; however, the higher-level organizations (i.e., state and national level organizations) that facilitated the project had previously worked together.

Capacity building and knowledge systems

The term, capacity building, is usually used to mean government, NGO or other technical people “educating” the local people. However, in our four cases, it is clear that such education is a two-way process: (1) government, NGO, and private sector personnel sharing technical information with community members, and (2) the latter sharing local knowledge with the former. Formal capacity building has been provided by both the major organization(s) involved in the project and many other organizations holding particular knowledge, which have been contracted by the project to carry out specific tasks.

Capacity building was a major factor in community organization and project implementation in all the cases. It was carried out through meetings, workshops, formal training programs in community organization and technical issues, and guided visits. In most, if not all, of the projects, the training that local people received has empowered them in economic terms as well as in social aspects, as in the case of women’s groups in India (see below).

One interesting aspect of capacity building as a two-way process was the establishment of informal ‘learning networks’ in some of the cases. In the Brazilian case, a multi-level network of people from a diverse set of organizations worked together to tackle new

problems during periodic meetings. In Guyana, several meetings involving the major organizations and scientists were designed to bring together local and scientific knowledge and experiences in a collaborative, problem-solving environment, as seem to be the case in adaptive co-management elsewhere (Olsson et al. 2004).

Indeed, one characteristic of all these projects is that they provided space to combine local and scientific knowledge to either improve resource management or human well-being. In the Brazilian case, local and technical knowledge were used together to improve oyster aquaculture technology.

In Guyana, the Arapaima management currently relies almost entirely on local knowledge, and the monitoring system based on local ecological knowledge uses a technique transferred from a project in Brazil. Monitoring is done by using a visual survey method. This method seems to be scientifically reliable and has been shown to be as effective as the scientific mark-recapture method (Castello 2004). Scientists provide support in the analysis and interpretation of survey data. It is expected that scientific knowledge will be used also in future management when fishing quotas are established.

The India project focused mainly on local knowledge about medicinal plants and their uses. However, the project staff also brought some technical/scientific knowledge into the project. There were three main sources of knowledge: (1) Ayurvedic knowledge (the classical Indian traditional knowledge documented in ancient scriptures which emerges as herbal cure alternative to allopathic medicines), (2) folk or traditional, un-codified knowledge passed on through oral transmission, some of which has been documented in databases, and (3) other type of local knowledge acquired by local forest department staff, project staff and community members.

In both of the Kenyan cases, HCA introduced a new technology (modern beehive) for beekeeping. In one area (KE-I), the communities already had extensive knowledge about bees and beekeeping, using traditional technologies, and only had to make minor adaptations to new technology. In the other area (KE-II), only few community members had some knowledge about bees and beekeeping using traditional technologies, and most of the individuals purchasing the HCA beehives had much to learn about beekeeping. Indeed, the lack of pre-existing local knowledge and beekeeping know-how is one of the factors that are constraining this project's success.

Leadership and key players

The key players and their roles have changed over time in all of the projects. In Brazil, a sequence of government agents/researchers played a leadership role throughout project design and implementation (**Table 1**). The project started with a researcher who moved from a university group to a government agency, bringing the project with him to this new organization. This first leader left the organization later, but his role was filled by a second leader, who worked closely with a third leader from another government technical body. The two organizations were the major outside ones involved in the project. When

the second leader left that government organization, another person assumed his role. At the local level, a community leader took the role of organizing community members to engage in the project. However, his role in the project has diminished, and other local leaders are emerging, such as the current head of the cooperative.

In the Guyana case, two of the three persons that were involved in the initial phase of the project are still (as of 2004) very active. One is the head of the fisheries committee who has played different roles in several organizations and group actions within the North Rupununi area. He is a very articulate communicator, and for many “he is the face of the Arapaima Management”. The other leader is the head of the national NGO (Iwokrama) involved in the project, and he has been key in establishing links between the NRDDDB and outside organizations such as research groups, government agencies and funding agencies. The third key person was a foreign scientist from the Mamirauá project, which served as a model for this one, but that is no longer working with the NRDDDB project due to lack of funding.

In the India case, the key people that started and facilitated the project implementation were people that occupied senior positions in their organizations, either in government or NGOs. Most of them are still providing their input in varying capacities to the project but their degree of involvement has been reduced. One of initial key player moved to a higher position within the state government, and was able to provide strong support to the project from a higher government level. At the local level, the key organizations are the local management committees (the heads of which shift over time) and the self-help groups of women.

In the Kenyan case, the entrepreneur who started HCA has played a special role: that of the visionary. In one of the cases, Kakamega, two persons stand out as leaders of the project. One is the head of the community-based organization partnering with HCA. The other leader is an experienced beekeeper who became a member of the partnering organization, leading to the establishment of a self-help group, and later became the HCA project officer in Kakamega. **Table 2** traces his changing roles and the connections he brings through three phases of the project. Two other people (international NGO agents) played a major role in connecting HCA with the partnering organization in the beginning of the project. In the Kwale case, no community leadership was identified, except for that provided by the partnering NGO and government agents working closely with this NGO.

In all the four cases, the role of outside agents of change, bringing new knowledge, ideas and/or technology to local people, was crucial for project success. It is interesting to note, however, that in the four cases, women play a minor role as agents of change and local leaders in formal organizations, government departments and NGOs. An exception is the Brazilian case, where the proportion of outside men and women leading the project was about the same. In all the other cases, leaders are male. At the community level in two of the cases (IN, KE-I), increasingly more women became involved in livelihood opportunities promoted by the project. Some of these women became local leaders within their own groups.

4. Cross-scale institutional linkages

Main institutional interactions

The study of cross-scale interactions is one of the two major objectives of our EI Research and Learning project. This section is concerned with cross-scale institutional linkages in the four cases, that is, horizontal linkages (those that connect the same or similar organizational levels across space or across sectors) and vertical linkages (those that connect across levels of organization).

How can the major cross-scale institutional linkages be characterized? **Figures 1 to 5** show the main interactions in the five cases: Brazil (BR), Guyana (GY), India (IN) and Kenya (KE-I and KE-II). The striking finding is that in all cases, institutional interactions cut across many levels. These projects are anything but isolated. They all operate at the local level, but tracing the important linkages with respect to funding, organization and key partnerships, one finds linkages all the way to the international level. Typically, there are five levels present. In all cases but one (GY), there is a local or community level; a regional or district level; a state or provincial level; a national level; and an international level.

The Guyana case has no state level. In the India case, the national level is not important in the main interactions but the State and protected area levels are active. Linkages are not equally important at all levels. For example, in the case of Kenya (KE-I and KE-II), there is a division level and a provincial level (**Tables 3 and 4**), but these two levels do not show up in the main linkages sketched in **Figures 4 and 5**. Thus, major links across four levels seem to be the norm, even though five or even six possible levels are present.

Linkages, networks and political support

Figures 1 to 5 distinguish between the stronger links and the weaker links among the main interactions. The striking finding here is that each EI case has certain key linkages that make the project possible. In the Brazil case, it is Forest Foundation and the Fisheries Institute, two agencies of Sao Paulo State Government acting in tandem, that connect the Cooperative with national and international funders. In the Guyana case, the supportive tandem is the national NGO, Iwokrama, and the District Board, NRDDB, which is not a government agency and which acts like an NGO. The India case is different: instead of a key supporting agencies, there is a network-like arrangement around RCMPCC at Pune. In the Kenya case, the local level is weak; some of the beekeepers are organized and some not. Again there is a supportive tandem. In KE-I, it is CARD, an NGO, acting with the HCA project officer.

The lesson from the Kenya cases is interesting in another way. Even though both KE-I and KE-II are HCA cases, the main players are different in the two. In KE-II, support

comes from CRSP, an NGO, acting with the District Office of a government department. In four of the five cases, there is one very strong horizontal linkage providing a tandem of support for the local level, and connecting it to sources of funding, information and other support. In the India case, the support has the form of a network, with the Pune Center at the middle. Of the main supporting organizations in each case, one finds both NGOs and government organizations. The key government agencies are always at state or district level, providing the extremely important function of political support.

In our four cases, they are not found at the national level; the central government seems passive or benign. It does not have much of a support function, but at least it does not create barriers either. In at least one of the cases (KE), we know that the organizers stay away from central government agencies and actively pursue partnerships with the district level government instead. One researcher characterized central agencies “as an omnipresent threat.” The State level, by contrast, is a key level in political support in two (BR, IN) of the four cases. In the India case, it is the State government that created a favorable policy environment (without creating new legislation) that led to the “issuing of government notification” to empower local groups and agencies to participate in the conservation of medicinal plants.

Funding and other resources

Just how do these key organizations connect the project at the local level to sources of funding and other resources? Unraveling the sources of funding is anything but simple. The larger picture hides operational complexities. Often, different sources are needed for different stages of the local operation or different functions of it. For example, **Figure 1** (BR) shows a “black box” of financial support. **Figure 6** shows the same Brazil case, but this time focusing only on the linkages that enabled the Cooperative to obtain health certification for its oysters. The resulting organizational chart is considerably more complex than **Figure 1** and provides a realistic picture of how the group went about seeking funds and where the funds went (designing the oyster depuration station; land for the station; construction materials and so on).

The Kenya case again holds a surprise. Even though both KE-I and KE-II are HCA cases, the funding sources are different. In KE-I, funds are coming through CARD, the NGO. But in KE-II, funds are coming through the national office of the Aga Khan Foundation, an international organization of Ismaili Muslims, and its district level program office.

Capacity-building and knowledge systems

How do the key organizations connect the project at the local level to sources of know-how, technical and practical information? On this point, the experience in each case is different. In the Brazil case, technical information came from NUPAUB (University of Sao Paulo), and the two State agencies. In the Guyana case, however, there was no knowledge available within Guyana. Iwokrama and the local fishers attempted to develop

a survey methodology that yielded inconclusive results. As a result, linkages were pursued with a reserve in Brazil, leading to the subsequent transfer and adaptation of Brazilian survey methodology to assess Arapaima populations using local knowledge and expertise. (The GY project area is inland, within the Amazon basin and not far from the Brazil border.)

In the India case, sources of information are from within the country but from a different part of the country. *In situ* conservation and cultivation of medicinal plants has become a big issue in many parts of India in recent years. Much of the technical knowledge came from south India through State level agencies but perhaps more importantly from FRLHT, an NGO based in Bangalore. In the Kenya case, the sources of information are diverse: there was a great deal of capacity-building, training in the use of modern beehives, using international knowledge. In KE-I, the role of local knowledge was important in the training of new beekeepers, whereas in KE-II (not a traditional bee-keeping area) little local knowledge existed.

In all cases, demonstration effect is important. This includes the HCA project officer who taught by example (KE-I); the vertical transfer of expertise with beehives through training; the visit by NGO and fishers in the GY case to learn how the Brazilians were counting Arapaima; and the horizontal transfer of medicinal plant conservation expertise through the NGO based in Bangalore (IN).

One additional aspect of capacity-building merits mention. In each of the EI cases, one finds spin-off groups and activities. In Brazil, for example, the organizational experience with the Cooperative resulted in the transfer of skills to establish a women's seamstress group. In Guyana, the experience with Arapaima problem solving led to the application of new skills to a range of other activities. In India, the project led to an increased appreciation of women's role in the conservation of medicinal plants, it spawned a variety of women's groups, and facilitated the increased participation of women in village political structures. As well, the project contributed to the revival of interest in traditional medicines; it had cultural implications, in addition to economic and environmental ones. Such revival was an outcome but also an objective of the project. In the four projects as a group, empowerment appears to be an important outcome, even though it is rarely an explicit objective of the project at the start.

Leadership and key players

Section 3 of this report details the leadership in the four projects. Two points can be made in this section with respect to cross-scale linkages. One is that leadership roles are consistent with the kind of linkages characterizing the case. In three of the four cases, there are individual leaders. In the fourth one (IN), linkages are in the form of a spoke-and-wheel and there is no one clear leader. Instead, there is a collective leadership of four or five people.

The second point is that the key people operate at multiple levels. That is, leaders do not seem to be active at only one particular level (e.g., the community). Rather, they seem to be straddling two or more levels of social and political organization, often making the linkages and translating local concerns to the levels above and *vice versa*. This mode of operation is consistent with what Cash and Moser (2000) refer to as “boundary organizations”, that is, groups (or in this case individuals) that translate findings or messages from one level of organization to another.

5. Conservation and biodiversity

The objective of the Equator Initiative is to address biodiversity conservation and poverty alleviation simultaneously. Hence, we pose two questions in this section. First, do the four cases here represent integrated conservation and development projects (ICDPs)? More specifically, do they measure up to the ideal of “integrated responses” (MA 2005) explicitly addressing more than one ecosystem service(s) and human well-being simultaneously? Second, what are the implications for conservation in this analysis of self-organization and cross-scale linkages?

On the first question, the four cases represent a range. The Guyana case has a major conservation component as well as an explicit development component, with deferred benefits (since Arapaima populations do not yet support a harvest). The India case, there is a clear conservation objective and a development objective, both visible in the field and both being addressed. In the Brazil and Kenya cases, the objectives do explicitly include both conservation and development. But in the field, it is clear that the business side of the project receives more attention, and is more documentable, than the conservation side.

Turning to the second question, we need to explore our findings a little more deeply with respect to the conservation question. One of the problems in the documentation of biodiversity conservation has to do with baseline documentation. One cannot show biodiversity conservation if one does not have the data, pre- and post-project. This problem is being addressed in the Guyana case through the development of a community-based monitoring program for Arapaima. In the India case as well, there now is the necessary set-up to obtain such baseline data. In the Brazil and Kenya cases, however, there are no conservation data and no provision to obtain such data. A complicating consideration is that environmental change is occurring through multiple drivers and not only through the (positive) impacts of the EI initiative.

One important conclusion from the GY and IN cases is the role of community-based monitoring. In both cases (1) monitoring did not exist pre-project, (2) it was developed as the project proceeded, (3) it was developed through some combination of local knowledge and outside expert knowledge, and (4) it was developed by learning and adaptive management (iterative learning-by-doing).

As direct evidence of biodiversity conservation is difficult to obtain, attention should also be paid to indirect evidence. In the four cases, such evidence includes:

- Reducing incentives for illegal forest harvest (KE, IN)
- Increased livelihood resilience through better incomes as a way of achieving conservation, through the reduction of pressure on vulnerable resources (KE)
- Conservation through threat reduction (GY, IN, KE)
- Conservation through bringing at-risk species and habitats under conservation controls (IN)
- Conservation through local people actually “looking after” the species or the habitat or both (GY, IN)
- Conservation through environmental education and increased awareness that conservation, livelihoods and community health go together (BR, GY, IN, KE).

6. Conclusions

The case studies are still being analyzed. Some tentative conclusions are offered here.

Community self-organization:

1. There were pre-existing relationships among some of the key groups involved in each initiative before the project started.
2. Three of the four projects were initiated from the outside, and only one was locally initiated. Nevertheless, all four projects developed by partnerships and feedback learning.
3. Funding is a key input; in our cases funding came from multiple sources. Fund-raising skills seem to be key to project success (except perhaps in IN case).
4. Funding may be very complex, with start-up funding and operational funding, and funding for different stages and different functions of the initiative.
5. Different parts of one EI initiative may have different funding sources (for example, KE-I and KE-II).
6. In evaluating if a project has become financially self-sustaining, it is important also to ask what services the project is delivering.
7. Mutual learning, learning networks and two-way education characterize learning in the four EI cases, rather than capacity-building in the sense of simple training.
8. There are key players in each initiative and their roles tend to change over time.
9. The role of outside agents of change, bringing new vision, knowledge and technology, is crucial.

Cross-scale institutional linkages:

10. Each initiative is multi-level, typically involving partnerships across four levels of organization.
11. There is one very strong horizontal linkage providing a tandem of support for each initiative; alternatively there is a network arrangement with the initiative in the hub of the network (IN).

12. The tandem of support is provided by NGOs and/or district or state-level government agencies.
13. Central governments are not directly involved in any of the four projects, but neither do they provide barriers.
14. The experience with horizontal and vertical linkages involved in capacity-building are different in each case.
15. Demonstration effect is important.
16. Organizational experience with a particular initiative tends to result in the transfer of skills to other areas and activities (e.g., women's groups), with spin-off effects not anticipated at the start of the initiative.
17. Leadership roles are consistent with the kind of linkages characterizing the case.
18. Leaders and key people operate at multiple levels, straddling two or more levels of organization.

Conservation and biodiversity:

19. Each of the four EI cases can properly be characterized as a conservation and development project (ICDP), each explicitly addressing more than one ecosystem service(s) and human well-being objective simultaneously (Millennium Assessment criteria for integrated responses).
20. There is a range of experience regarding the extent to which conservation objectives are visible in the field; in two cases, conservation objectives are in the forefront, in the other two they are not.
21. Community-based monitoring, now in place in two of the cases (GY, IN) is important for the documentation of conservation benefits.
22. In both cases (GY, IN) such monitoring did not exist before the project; it was developed as the project proceeded.
23. Both of these emergent monitoring systems were developed by combining local knowledge and expert knowledge and by adaptive management (learning-by-doing).
24. Attention should be paid to indirect evidence of conservation. These may include reduced incentives for illegal harvests; conservation through threat reduction; conservation through local people actually "looking after" species and habitats; and environmental education and increased awareness.

References

- Agrawal, A. 2002. Common resources and institutional sustainability. In: *Drama of the Commons* (E. Ostrom, T. Dietz, N. Dolsak, P.C. Stern, S. Stonich and E.U. Weber, editors. National Academy Press, Washington DC, pp. 41-85.
- Barrett, C.B., K. Brandon, C. Gibson, and H. Gjertsen. 2001. Conserving tropical biodiversity amid weak institutions. *BioScience* 51: 497-502.
- Berkes, F. 2004. Rethinking community-based conservation. *Conservation Biology* 18: 621-630.
- Berkes, F., J. Colding, and C. Folke, editors. 2003. *Navigating Social-Ecological Systems: Building Resilience for Complexity and Change*. Cambridge University Press, Cambridge.
- Brown, K. 2002. Innovations for conservation and development. *The Geographical Journal* 168: 6-17.
- Cash, D.W. and S.C. Moser 2000. Linking global and local scales: designing dynamic assessment and management processes. *Global Environmental Change* 10: 109-120.
- Castello, L. 2004. A method to count pirarucu *Arapaima gigas*: Fishers, assessment, and management. *North American Journal of Fisheries Management* 24: 379-389.
- EI 2004. Equator Initiative web site. (<http://www.undp.org/equatorinitiative>)
- Hooper, M., R. Jafry, M. Marolla and J. Phan 2004. The role of community scaling-up in achieving MDFs: An assessment of experience from the Equator Prize. *Between the Lines* (Nov. 2004) (<http://www.undp.org/equatorinitiative>)
- Isely, C. and S. Scheer. 2003. Community-based ecoagriculture initiatives: Findings from the 2002 UNDP Equator Prize Nominations. *Equator Initiative draft report* (<http://www.undp.org/equatorinitiative/docs/EcoAgDraftReport.doc>)
- Jonas, N.M.S. 2003. Key factors leading to successful sustainable community livelihoods: Lessons learned and research option based on the desk analysis of winning Equator Prize 2002 projects. *Equator Initiative Working Paper*. (<http://www.undp.org/equatorinitiative/secondary/knowledge/IRDC.htm>)
- Juma, C and V. Timmer. 2003. Social Learning and Entrepreneurship: A Framework for Analyzing the Equator Initiative and the 2002 Equator Prize Finalists. *Working paper* (www.ksg.harvard.edu/sed)
- Ludwig, D. 2001. The era of management is over. *Ecosystems* 4: 758-764.
- MA 2003. *Ecosystems and Human Well-being: A framework for assessment*. Millennium Ecosystem Assessment. World Resources Institute/Island Press: Washington, DC.
- MA 2005. *Ecosystems and Human Well-being: Responses Assessment, Chapter 15*. Millennium Ecosystem Assessment. World Resources Institute/Island Press: Washington, DC (in press).
- Olsson P., C. Folke and F. Berkes 2004. Adaptive co-management for building resilience in social-ecological systems. *Environmental Management* 34: 75-90.
- Seixas, C.S., B. Davy and W. Leppan. Lessons learnt on community-based conservation and development from the 2004 Equator Prize finalists (Submitted to the *Canadian Journal of Development Studies*).
- Young, O. 2002. *The Institutional Dimensions of Environmental Change: Fit, Interplay and Scale*. MIT Press, Cambridge, MA.

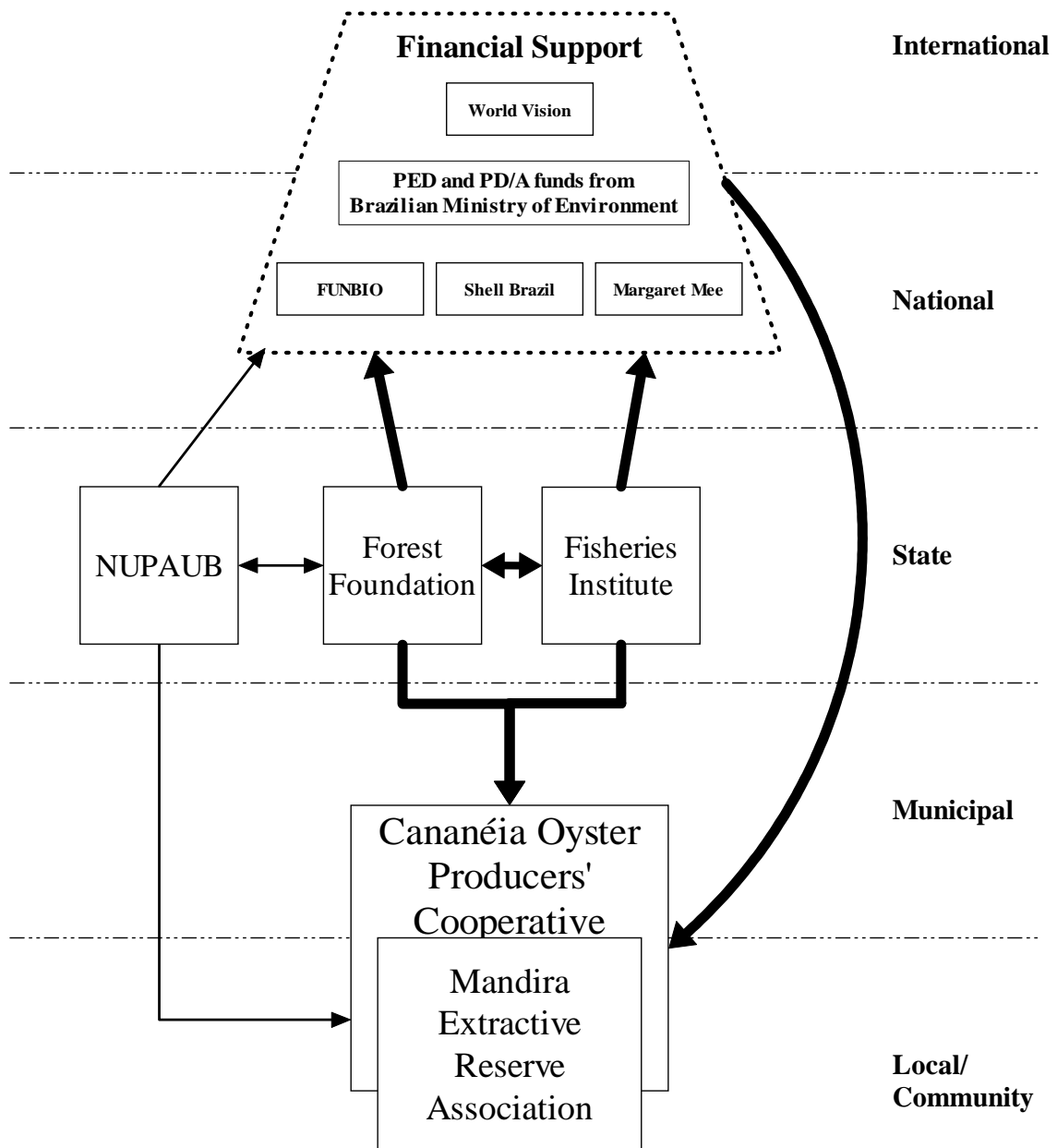

Figure 1. Key institutional cross-scale linkages that facilitated creation and development of the Cananéia Oyster Producers' Cooperative (Source: Medeiros 2004).

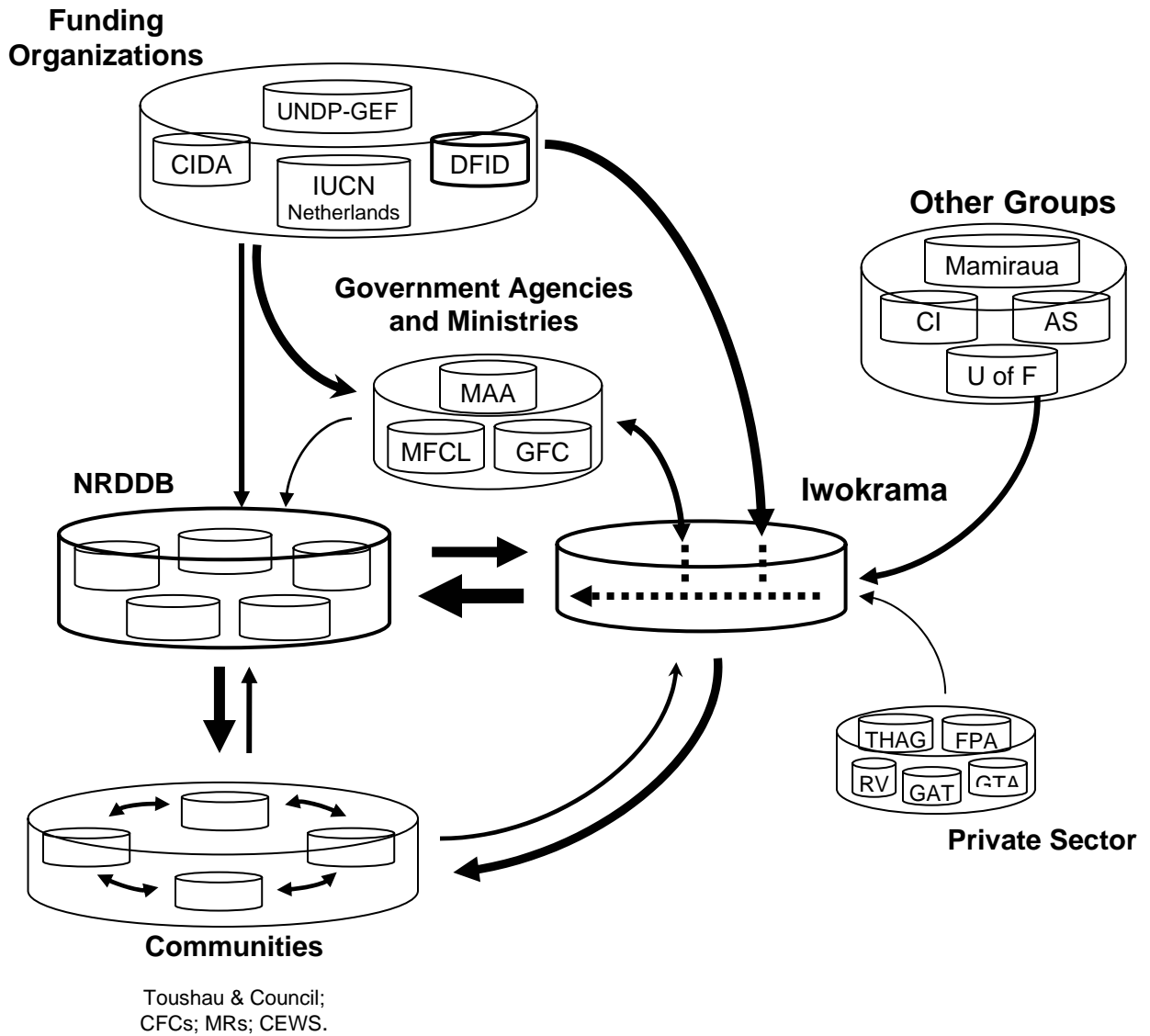

Figure 2. Key institutional linkages facilitating the activities of the North Rupununi District Development Board (NRDDB). Source: Fernandes (2004)

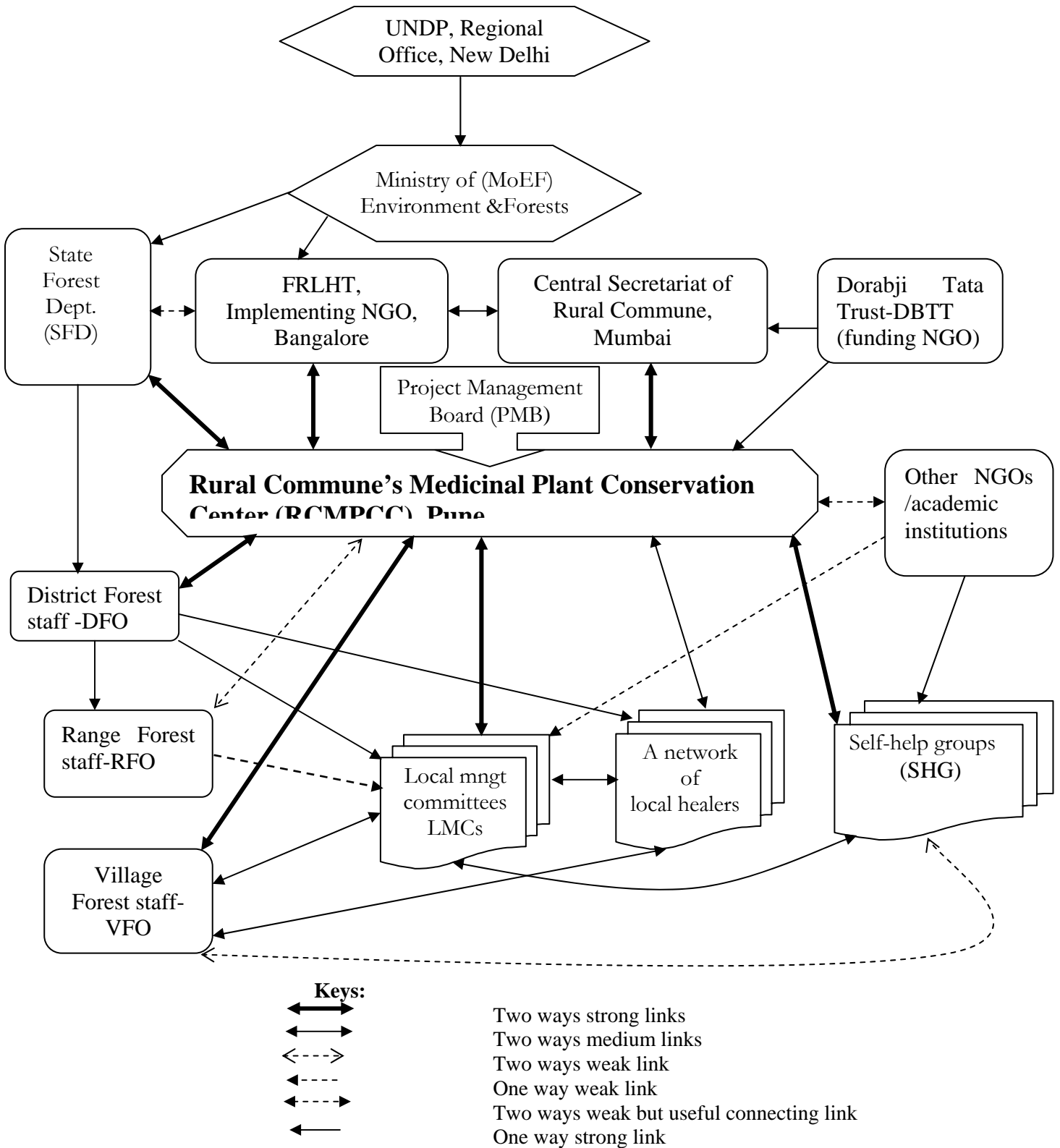

Figure 3: Enabling cross-scale linkages helped achieve project goals, Rural Communes' Medicinal Plant Conservation Center, Pune, India. Source: Shukla (2004)

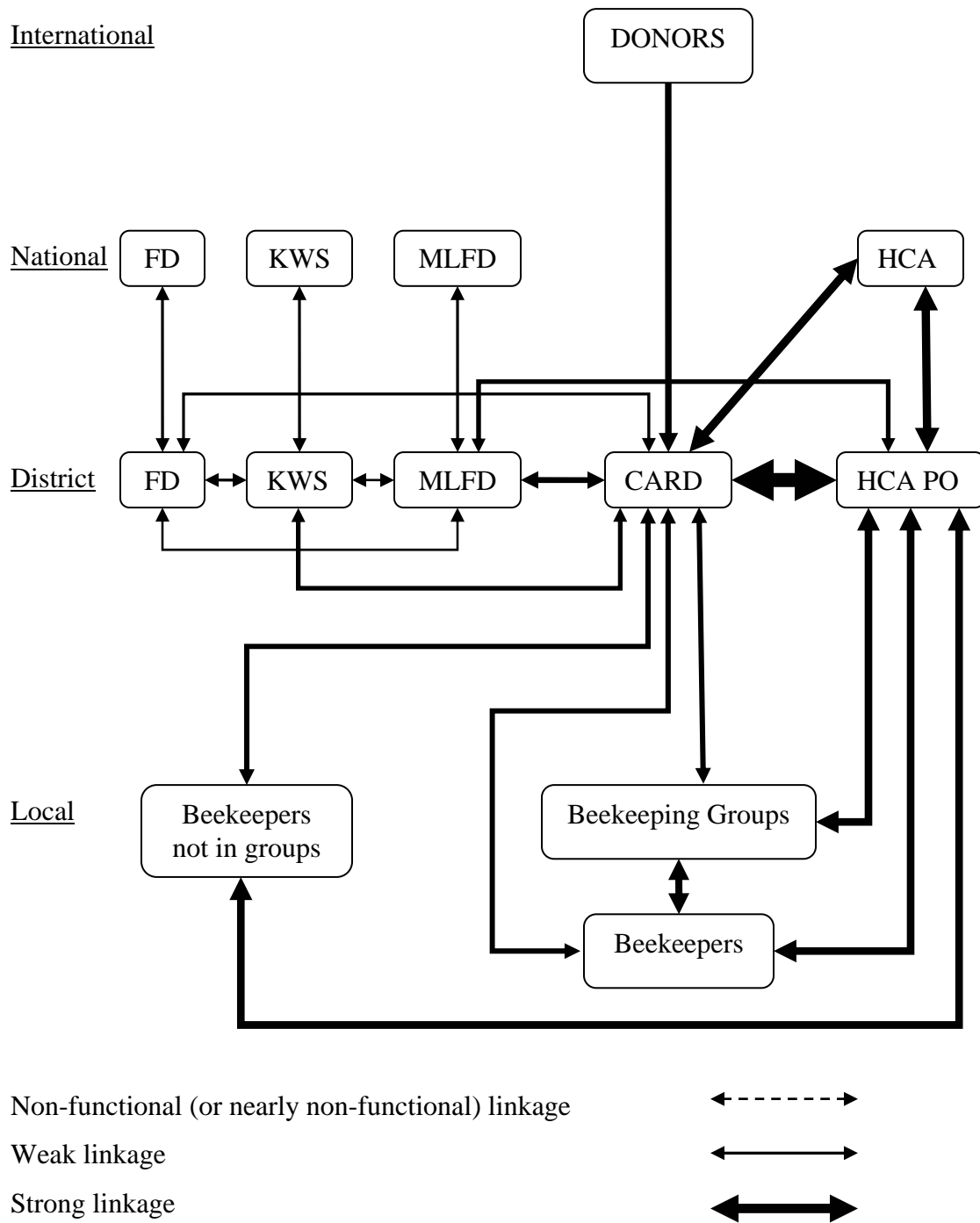

Figure 4: Cross-Scale interactions of stakeholders in Kakamega HCA project. FD: Forest Department; KWS: Kenya Wildlife Service; MLFD: Ministry of Livestock and Fisheries Development; HCA: Honey Care Africa; HCA PO: Project Officer; CARD: Community Action for Rural Development (community-based organization). Source: Maurice (2004)

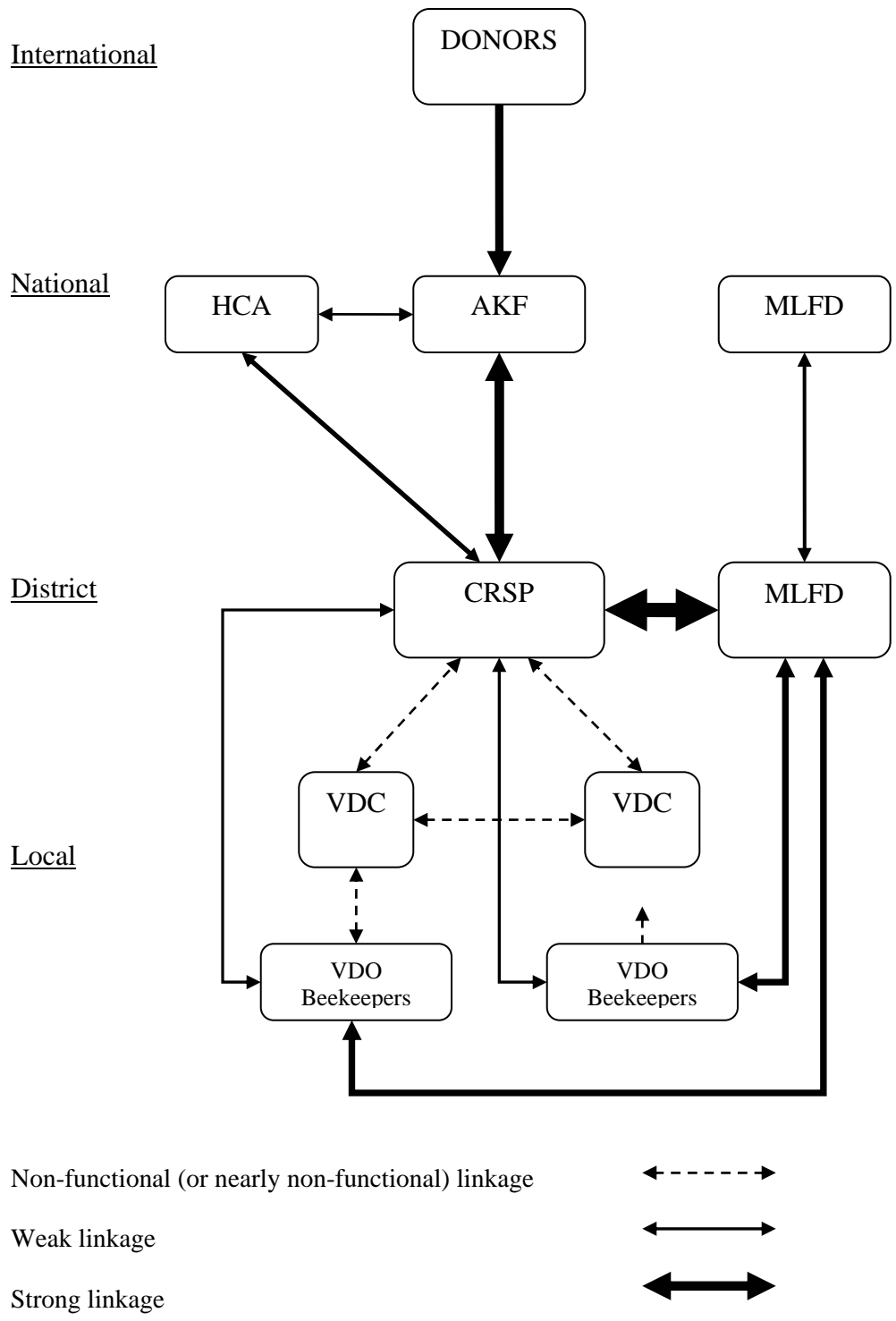

Figure 5: Cross-Scale interactions of stakeholders in Kwale HCA project. HCA: Honey Care Africa; AKF: Aga Kan Foundation (National NGO); MLFD: Ministry of Livestock and Fisheries Development; CRSP: Coastal Rural Support Program of AKF; VDC: Village Development Committee; VDO: Village Development Organization. Source: S. Maurice (2004)

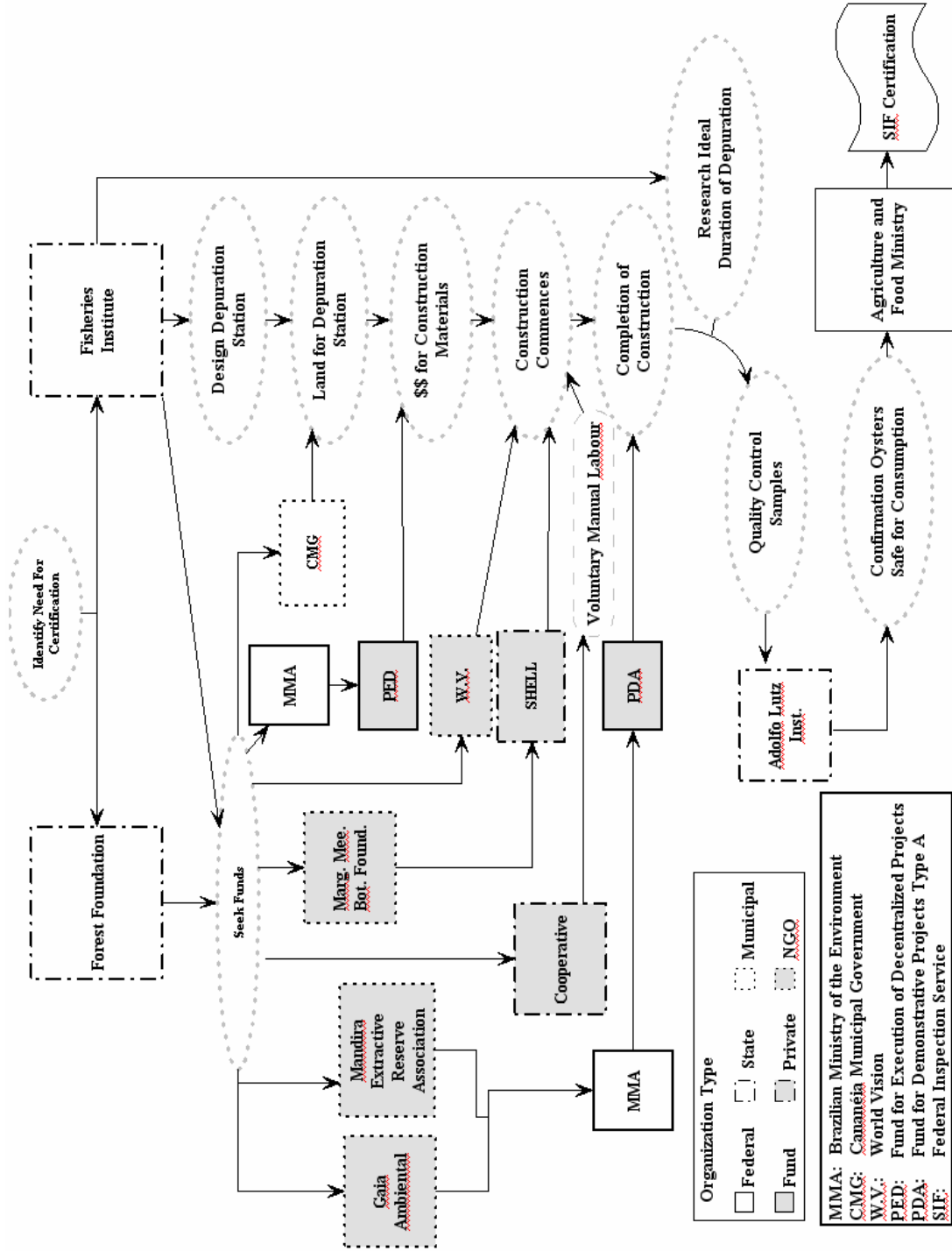

Figure 6. Organizational cross-scale linkages which enabled the Cooperative to obtain health certification from the Federal Inspection Service for its oysters (Source: Medeiros 2004).

Table 1: External leaders and their roles, affiliation and connections in the Brazilian case. Source: D. Medeiros.

	PHASE				
Phase	I	II	III	IV	V
External Leader	Leader I (1990-1996)		Leader II (1995-1999)	Leader IV (2000-mid2004)	Leader V (mid2004 – present)
Organization Affiliation	State University Research Institute	State Forest Foundation	State Forest Foundation	State Forest Foundation	State Forest Foundation
Role	grad student: research socio-ecological viability of extractive reserve	government researcher: start attempt to implement the extractive reserve	government researchers: contact all oyster harvesters, initiate cooperative	government researchers: capacity development of oyster harvesters, establish extractive reserve	government researchers: assist Cooperative secure a market
Connections	Environmental Ministry, State Secretariat of the Environment [which encompasses State Forest Foundation]	State University Research Institute, State Fisheries Institute, Community-Based Organization, Leader II and III,	State University Research Institute, State Health Organization, Municipal Government, Local NGO, Local Religious Organization, Leader IV	National and International Funding, State University Research Institute, State Health Organization, Local NGO, Education Agent, Economic Planning Agent, Market Development Agent, Leader V	National Funding, State Health Organization, Market Development Agent

Table 2: Role of key individuals: Honey Care Africa Project Officer, Kakamega, Kenya.
Source: S. Maurice.

	Phase I (2000 - 2002)	Phase II (2002 – 2003)	Phase III (2003 – Present)
Organization	CARD	CARD	HCA
Affiliation		IBG	CARD IBG
Role in Organization	Individual Beekeeper	CARD Beekeeping Officer; IBG Chairperson	HCA Project Officer; IBG Chairperson
Connections - Contacts		Beekeepers (Village level); MLFD Divisional Officer	Beekeepers (District level); MLFD Divisional Officer, MLFD District Officer

HCA: Honey Care

CARD: Community Action for Rural Development (Community-based organization)

IBG: Ivihiga Beehive Group

MLFD: Ministry of Livestock and Fisheries Development.

Table 3: Cross-scale representation of stakeholders in Kakamega HCA project, Kenya.

Source: S. Maurice.

	Local	Division	District	Province	National	International
Honey Care					X	
HCA PO			X			
CARD			X			
Local Groups	X					
Forest Dept					X	
KWS					X	
Livestock/Agr					X	

HCA PO: Honey Care Project Officer

CARD: Community Action for Rural Development (Community-based organization)

KWS: Kenya Wildlife Services

MLFD: Ministry of Livestock and Fisheries Development.

X

Level at which institution is based

Level at which institution is active in relation to the HCA project

Level at which institution is not active in relation to the HCA project

Table 4: Cross-scale representation of stakeholders in Kwale HCA project, Kenya.

Source: S. Maurice.

	Local	Division	District	Province	National	International
Honey Care					X	
CRSP			X			
AKF					X	
VDC	X					
VDO	X					
MLFD					X	

AKF: Aga Khan Foundation (National NGO)

CRSP: Coastal Rural Support Program of AKF

VDC: Village Development Committee

VDO: Village Development Organization

MLFD: Ministry of Livestock and Fisheries Development

X

Level at which institution is based

Level at which institution is active in relation to the HCA project

Level at which institution is not active in relation to the HCA project